

1E4351 | MRS BO WALL

Wall mounted LED fixture with radial emission available as Angled version for an elliptical asymmetric light effect

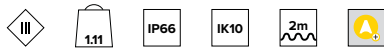
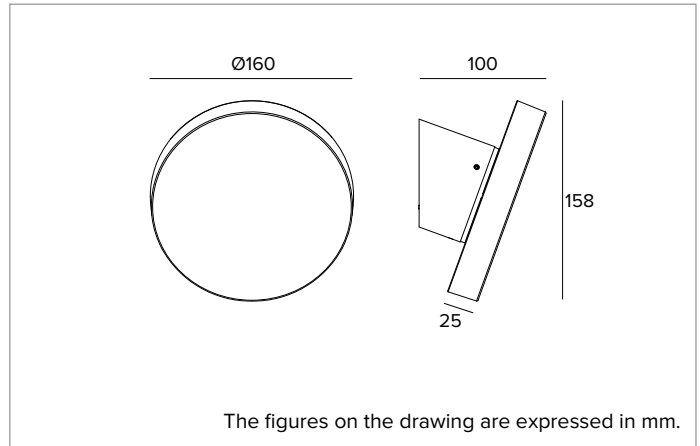

	3500K	H(m)	D1(m)	D2(m)	E _{max} (lx)		
	Ra80	118°	117°				
Fixture Power	10W	1	5.43	3.47	119		
Source Flux	1364lm	2	10.85	6.94	30		
Fixture Flux	383lm	3	16.28	10.41	13		
Efficacy	39lm/W	4	21.71	13.89	7		
TS1788	I _{max} =97cd/klm	I _{max}	132cd	5	27.13	17.36	5

**SOURCE**

High efficiency Chip on Board LED Ra80. Ra90 on request.

Energy efficiency class: E

Nominal power: 8,8W

Nominal flux: 1364lm

Colour rendering index: 80

Rf: 83

Rg: 95

CCT nominal: 3500K

Lifetime (L80/B10): >50000h tq +25°C

ILLUMINOTECHNICAL CHARACTERISTICS

A high reflectance anodised aluminium printed reflector. Opal polycarbonate diffusive screen.

Emission: ELLIPTICAL

Optic: REFLECTOR

Optical efficiency: 28%

Fixture flux: 383lm

Luminous efficacy: 39lm/W

Photobiological safety: Compliant with RG1 low risk group

MECHANICAL CHARACTERISTICS

Anodized die-cast aluminium powder coated optical head. Wall mounting bracket (included in the product) in aluminum with cataphoresis protective treatment and coated with powder painting.

Colour and finish: Ferrite

Dimensions: Ø 160mm

Weight: 1.11Kg

Degree of protection: IP66

Mechanical Resistance: IK10

ELECTRICAL CHARACTERISTICS

To be completed with special 24Vdc driver. Casambi control system available using a dedicated accessory (only with DALI dimmer).

Fixture Power: 10W

Power supply: 24Vdc

Insulation Class: CLASS 3

Driver included: NO

Class F: YES

Ambient temperature: 0°C / +35°C

INSTALLATION

Stainless steel recessed-mounting box for housing the connection terminal block available as an accessory.

NOTES

Uses the "Waterblock Smart" technical solution that involves resin coating the connection cables, limiting the risk of humidity reaching the driver or the fixture. It is possible to subject the product to Cataphoresis treatment on request. Commissioning of the control system via free APP; the intervention of a specialist technician can be quoted on request.

WARRANTY

5 years.

WARNING

Luminaire designed for disposal/recycling at end-of-life. Replaceable (LED only) light source by a professional.

Due to the technological evolution of the electronic components, the data provided may be updated, and as such, confirmation must be requested during the order process.

Luminous flux and power supply have +/-10% tolerances with respect to the indicated value. tq +25°C (CIE 121).

We reserve the right to make technical changes.

Targetti Sankey S.r.l.
Via Pratese, 164
50145 Firenze - Italy
Tel: +39 055 37911
targetti.com
targetti@targetti.com

CCIAA Firenze
Share Capital:
€ 500.000,00
VAT N. (IT):
01537660480
R.E.A: FI-275656

TARGETTI

1E4351 | MRS BO WALL

Wall mounted LED fixture with radial emission available as Angled version for an elliptical asymmetric light effect

Related codes

Power Supply

Dimensions LxHxP mm	Power	Power supply	Output voltage	IP	Code
79x25x38	14,4W	220-240Vac	24Vdc	IP67	1E4359
185x22x64	50W	220-240Vac	24Vdc	IP20	1T3726
140x32x63	75W	220-240Vac	24Vdc	IP67	1T3586
230x87x43	100W	220-240Vac	24Vdc	IP67	1T3587
238x42x67	200W	220-240Vac	24Vdc	IP67	1T3588

Electronic ON-OFF power supply.

Accessories

Insertion Box



Code

1E4357

Outer casing for electrical connections.

Connector



Code

1E4358

Connection box - Connection in parallel 1IN-2OUT.

Control systems

Code

1T6581

Dimmer for 12-24Vdc constant voltage LED driver.
1-10V/DALI control input.
IP20

Code

1E3048

IP67 wireless control unit with DALI interface.
It generates a local DALI2 bus, enabling a direct connection to a DALI interface LED driver.
The module can only be used in a closed system and cannot be connected to an existing DALI network.
The module is wireless controlled using a Casambi app for smartphones and tablets using Bluetooth 5.0 technology.
The devices automatically create an adaptive, robust, and reliable wireless mesh network, allowing for the easy and efficient management of a high number of fixtures.
The control unit is preset to the DALI 1CH profile, meaning the device can control a single DALI driver with broadcast commands.
In addition to the DALI broadcast, other operating modes are available, such as:

- Button (normally open)
- Control unit 0/1-10V
- Control unit DALI Tunable White DT8
- Presence sensor

Due to the technological evolution of the electronic components, the data provided may be updated, and as such, confirmation must be requested during the order process.

Luminous flux and power supply have +/-10% tolerances with respect to the indicated value. tq +25°C (CIE 121).

We reserve the right to make technical changes.

Targetti Sankey S.r.l.
Via Pratese, 164
50145 Firenze - Italy
Tel: +39 055 37911
targetti.com
targetti@targetti.com

CCIAA Firenze
Share Capital:
€ 500.000,00
VAT N. (IT):
01537660480
R.E.A.: FI-275656

TARGETTI

1E4351 | MRS BO WALL**Wall mounted LED fixture with radial emission available as Angled version for an elliptical asymmetric light effect****Control systems**

Code

1E4369

IP67 Extender for wireless control of LED driver with dimming DALI interface based on Casambi technology.

It has a DALI2 output with the capacity to control up to 40 lighting fixtures.

With the addition of a further external BUS DALI power supply it is possible to control up to 64 fixtures.

IP67 Extender is preset to the DALI broadcast profile, meaning all the luminaires connected to it are dimmable at the same level.

In addition to the DALI broadcast other operating modes are available, such as:

- EXTENDER DALI 8CH
- EXTENDER DALI Tunable White
- EXTENDER DALI 4CH
- EXTENDER DALI DT8 Tunable White

Due to the technological evolution of the electronic components, the data provided may be updated, and as such, confirmation must be requested during the order process.

Luminous flux and power supply have +/-10% tolerances with respect to the indicated value. tq +25°C (CIE 121).

We reserve the right to make technical changes.

Targetti Sankey S.r.l.
Via Pratese, 164
50145 Firenze - Italy
Tel: +39 055 37911
targetti.com
targetti@targetti.com

CCIAA Firenze
Share Capital:
€ 500.000,00
VAT N. (IT):
01537660480
R.E.A: FI-275656

TARGETTI